

USER GUIDE FOR 24MM SPINDLE SRM ORIGIN ONLY

POWERMETER INSTALLATION

⚠ NOTICE

It is recommended that you have the SRM PowerMeter installed by an authorized dealer. To locate an SRM authorized dealer visit our website at www.SRM.de. Do not use a mallet to install the PowerMeter as this can damage the electronics which is not covered under warranty.

Inspection before installation

- Please check that the chain catcher pin of the big chainring aligns with the drive-side crankarm.
- Make sure the chainrings sit flat and tight on the 110mm BCD (bolt circle diameter) of the PowerMeter.
- Check chainrings bolts of the SRM ORIGIN PowerMeter are torqued to the correct specifications:
 - Shimano chainrings - **12Nm**
 - Other manufacturers - **8 - 10Nm** (check manufacturer specifications)
- The drive-side crankarm comes pre-installed at the correct torque specification.

⚠ WARNING

Do not loosen the pinch or crank bolt on the drive-side crank! Doing so may result in damage to the product which could result in injury or death.

PowerMeter Installation

⚠ WARNING

Failure to observe the proper torque specifications can result in damage to the product which can result in injury or death.

- Ensure frame has a suitable 24mm bottom bracket installed when mounting the SRM ORIGIN 24mm PowerMeter. Compatible bottom brackets can also be purchased from SRM authorized dealers or our online shop at: www.SRM.de.
- Install bottom bracket per manufacturer's instructions, ensuring sealing rings are placed properly and bearings are fully seated and concentric in frame.
- Apply a small amount of grease to the contact surfaces of the bearing/axle before installing drive-side crank. Due to tight tolerances, the axle/bottom bracket can be difficult to install if not inserted straight. Carefully align the spindle with both bearings and with a slight rocking motion use light pressure to fully seat crank in the bottom bracket. Make sure the non-drive side bottom bracket does not come loose or come out of the BB shell.
- Install the Ø22 x 3mm o-ring on the non-drive side before adding the crank reducer (Fig. 1).
- Apply grease to axle and install non-drive crank reducer till it contacts the o-ring (Fig. 2). Next install the non-drive crank, making sure that the crank is rotated 180° to the drive-side crank arm. **Slits in the reducer and non-drive crank MUST be aligned (Fig. 3).**
- Apply a light thread locker (violet) to the threads of the 10mm axle bolt and tighten counterclockwise (left-handed thread) slightly with a 10mm Allen key (Fig. 3) until the spacers touch the o-ring and the crank is free of axial play.

⚠ NOTICE

Excessively high tightening forces can bring lateral pressure to the bearing and lead to increased bearing wear and possibly damage the bottom bracket over time.

- Unscrew the 3mm non-drive side crank pinch bolt and place a small drop of light thread locker (violet) on the threads. Center barrel nuts in crank and torque to **max. 4-5Nm** (Fig. 4.1). **Ensure barrel nuts remain centered in crank while torquing 3mm pinch bolt.**
- Tighten the 10mm left axle bolt counterclockwise (left-handed thread) with a torque of **5Nm** (Fig. 4.2). Let the thread locker cure for at least 6 hours before use!

Pedal installation / Choose crank length

- The crank length can get adjusted from 170, 172.5 to 175mm. Make sure you select the correct crank length!
- Degrease and clean the Tri-lobe nut, Tri-lobe washer and the contacting crank surfaces. Dust and/or any other particles on the Tri-lobe nut or on the crank could damage the crank or the pedal threads.
- Make sure to use the correct Tri-lobe nut marked with "R" when installing the Drive-Side pedal (Fig. 5).
- Position the arrow on the Tri-lobe washer facing the marking of the desired length. Make sure the washer is aligned correctly and sitting flush inside the crank (Fig. 6). Insert the Tri-lobe nut from the backside. Make sure the holes of the washer and nut are concentric with each other.
- Repeat the installation process with the Tri-lobe nut marked "L" on the Non-Drive side crank arm (Fig. 7).
- Tighten the pedals with the recommended torque: **20 - 40Nm** (Insufficient torque could allow pedal to come loose, possibly causing damage to crank-arm, injury or death).

⚠ WARNING

Failure to observe the correct torque specification can result in damage to the product which can result in injury or death. Danger of accident due to failure of the crank system due to loosened screw connections. Check the correct torque specifications of all screw connections after the first 100km ride and then at regular intervals of 2.500km. If necessary, re-tighten the screws and/or replace thread locker if necessary!

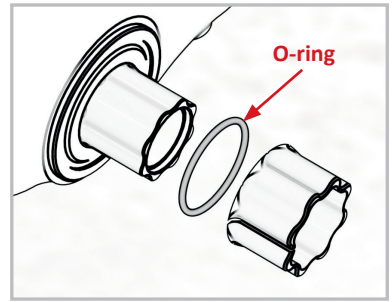

FIG. 1

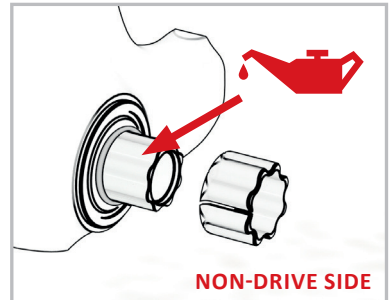

FIG. 2

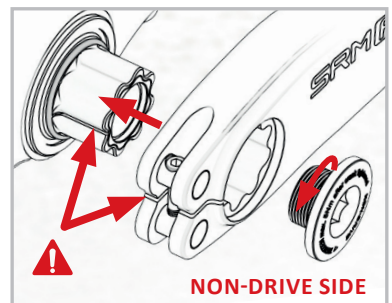

FIG. 3

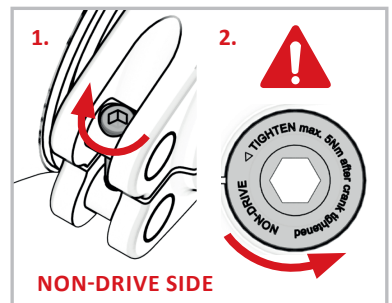

FIG. 4

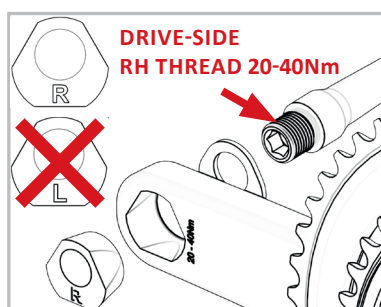

FIG. 5

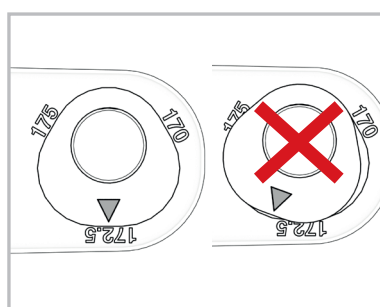

FIG. 6

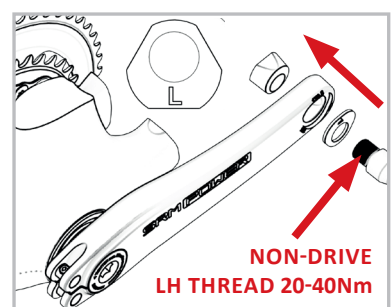

FIG. 7

Before assembly

- The cadence magnet must be installed properly in order for the PowerMeter to turn on and measure cadence.
- The recommended position for the cadence magnet is on the underside of the bottom bracket.
- Make sure the magnet is positioned between 21-51 mm from the center point of the bottom bracket shell. (Fig. 7).
- If your frame geometry does not allow for these magnet positions, visit our store at www.SRM.de for integrated chain catcher magnets and additional mounting options.

Option 1: For frames with a cable guide

- Remove the cable guide bolt and install the magnet under the cable guide (Fig. 8).
- To assist with cable guide removal, shift the chain into the largest cog in the rear and the largest chainring in the front. Next, without turning the cranks, shift both derailleurs to the smallest cog. This will remove tension from both cables.
- Position the magnet 4-6 mm from the backside of the PowerMeter (Fig. 9).
- Install the bolt and tighten it to the torque specified by the frame manufacturer - you may need a longer screw to securely hold the cable guide and magnet in place.

⚠ NOTICE

The derailleurs may require some adjustment after cadence magnet installation.

Option 2: For frames without a cable guide

- Clean both the magnet and the mounting surface of the frame with the isopropanol alcohol.
- Position the magnet 4-6 mm from the backside of the PowerMeter (Fig. 10).

⚠ NOTICE

It is recommended to temporarily fix the magnet in place and confirm correct position before installing with the double sided tape. Check the functionality of the PowerMeter before gluing the magnet!

- Use the double sided tape to install the cadence magnet to the frame. Remove the protective film on each side of the tape. Avoid touching the adhesive surfaces. Glue the magnet in the correct position.
- To achieve optimal magnet position, the cadence magnet and double sided tape can be cut with scissors to fit your desired location.

CONNECTION

- For information on connecting the SRM ORIGIN PowerMeter to your SRM PowerControl or other third party ANT+ devices, please refer to the device manual.

⚠ NOTICE

Make sure your PowerMeter is turned on when pairing to other devices! Spin the crank 1-2 revolutions to turn the PowerMeter on! Check cadence magnet placement to ensure function!

BATTERY TEST / REPLACEMENT

- The SRM ORIGIN PowerMeter broadcasts the battery status to the SRM PowerControl or other compatible ANT+ devices. You will get notified if the battery is running low!
- See our authorized dealers or us directly at www.SRM.de for a battery replacement.

⚠ WARNING

Danger of explosion, in case of improper opening of the PowerMeter or replacement of the battery.

⚠ NOTICE

Unauthorized opening and closing of the PowerMeter can lead to water leakage and permanently damage. The SRM ORIGIN PowerMeter is equipped with lithium batteries which can only get replaced by authorized SRM Dealers or the SRM Service Centers!

WARRANTY

Extent of Limited Warranty: SRM warrants to the end-user customer that the SRM products are free from defects in materials and workmanship for a 2-year duration after the date of purchase by the customer. The complete SRM warranty can be found online at www.SRM.de.

DISCLAIMER

CE - The CE mark is used to mark conformity with the European Union EMC directives EN 301 489-1 V1.81, EN 301 489-3 V1.41 and EN300 440-2 V1.3.1.

FCC compliance - This device complies with Part 15 of the FCC Rules. Operation is subject to the following two conditions: (1) this device may not cause harmful interference, and (2) this device must accept any interference received, including interference that may cause undesired operation. Repairs should be made by authorized SRM service personnel. Unauthorized repairs will void warranty. This product has been tested to comply with FCC standards and is intended for personal use only.

DISPOSAL OF THE DEVICE



Dispose of this device according to local and federal regulations, treating it as electronic waste. You may return this device to your nearest SRM Service Center for proper disposal.

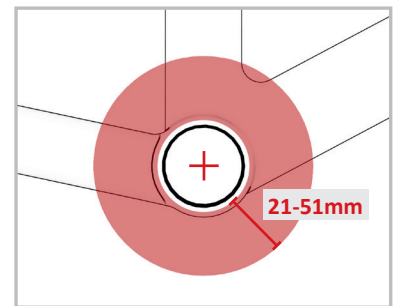

FIG. 7

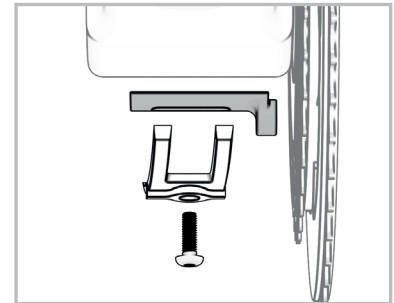

FIG. 8

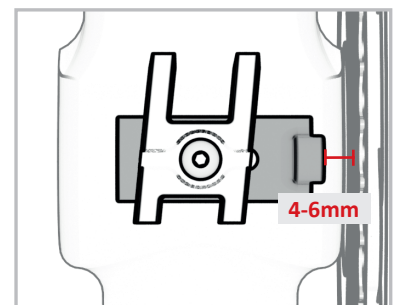

FIG. 9

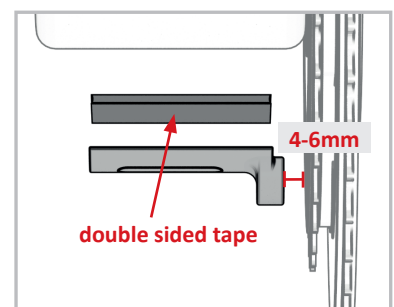

FIG. 10